

# LARA



## MV CAPACITIVE VOLTAGE INDICATORS



**LARA Elektromekanik Sanayi ve tic.ltd.**

Akan sokak, Yeni Darıca Küçük Sanayi sitesi:2, No:20, 41700-DARICA/Kocaeli – Türkiye

[www.laraelectromechanical.com](http://www.laraelectromechanical.com)

**LARA Elektromekanik Sanayi ve tic.ltd.**

Akan sokak, Yeni Darıca Kk Sanayi sitesi:2, No:20, 41700-DARICA/Kocaeli – Trkiye

[www.laraelectromechanical.com](http://www.laraelectromechanical.com)

INDEX

Type		Test Button	Display	Page
HR Voltage Indicator : CVI E	without relay	-	Led	2
HR Voltage Indicator : CVI L	without relay	-	Led	3
LRM Voltage Indicator: CVI	without relay	-	Small Lcd	4
LRM Voltage Indicator: CVI +	without relay	X	Large Lcd	5
LRM Voltage Indicator: CVI S1	1 relay	-	Small Lcd	6 - 7
LRM Voltage Indicator: CVI + S1	1 relay	X	Large Lcd	8 - 9
LRM Voltage Indicator: CVI + S2	2 relays	X	Large Lcd	10 - 11 - 12
Phase Indicator: CVI T	-	-	-	13
Resonance Damper	-	-	-	14 - 15



Voltage Indicator connection:

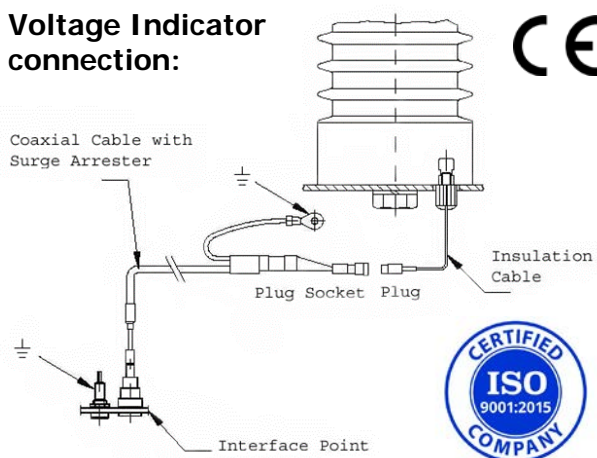

## HR Voltage Indicator: CVI E

The Voltage Indicator is designed for to use with MV capacitive voltage divider devices to indicate system power status.

### Features:

- System monitoring with safety (HR System)
- No auxiliary power is needed for voltage detection
- Bright and long-life LED to indicate
- Easy for installation and maintenance
- 4 connection leads for measuring at front panel
- Economical alternative



### Technical Parameters:

1. Operating voltage : 2kV-40kV with capacitive voltage divider
2. Rated frequency : 50Hz or 60Hz
3. Ambient temperature range : -25°C to +55°C
4. Protection class : IP20
5. Dimension : 36 x 62 x 45mm
6. Weight : 0,05kg

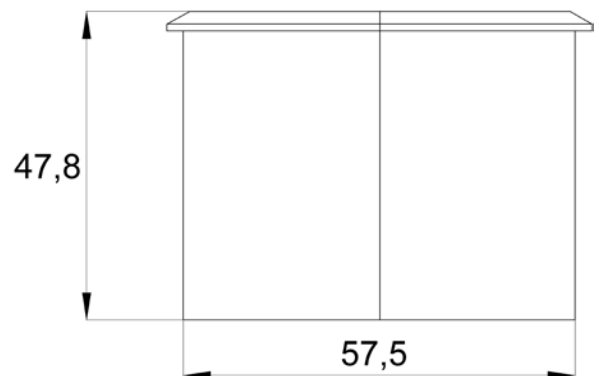
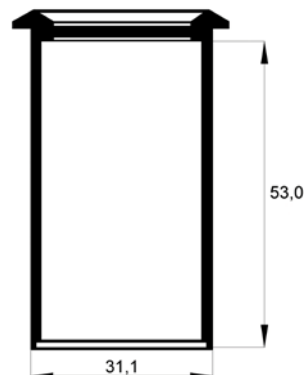
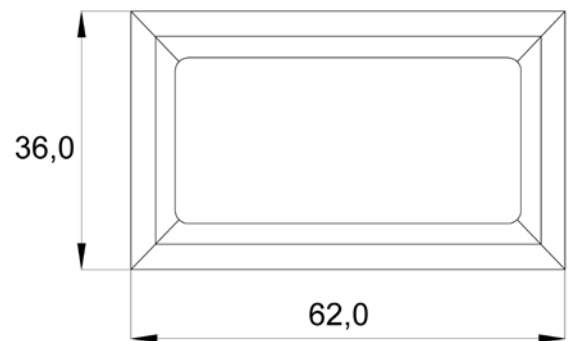

## HR Voltage Indicator: CVI L

The Capacitive Voltage Indicator is designed for to use with MV capacitive voltage divider devices. Three LEDs on the voltage indicators allow you to see if any voltage is present or absent in the system.



### Features:

- HR system
- According to IEC 62271-213
- No auxiliary power is needed for voltage detection
- 3 Phase flashing LED indication
- 4 testing measuring points on front side
- Easy for installation and maintenance
- Economical alternative

### Technical Parameters:

- |                                      |                               |
|--------------------------------------|-------------------------------|
| 1. Rated frequency                   | : 50Hz or 60Hz                |
| 2. Threshold voltage                 | : 10% to 45%Un                |
| 3. Operating temperature             | : -25°C to +55°C              |
| 4. Storage temperature               | : -30°C to +80°C              |
| 5. Protection class                  | : IP54                        |
| 6. Power freq. withstanding voltage: | 2kV/1min                      |
| 7. Connection leads                  | : 4.8*0.8mm fast-on terminals |
| 8. Dimension                         | : 96*50*50mm                  |
| 9. Cutting size                      | : 91*45mm                     |

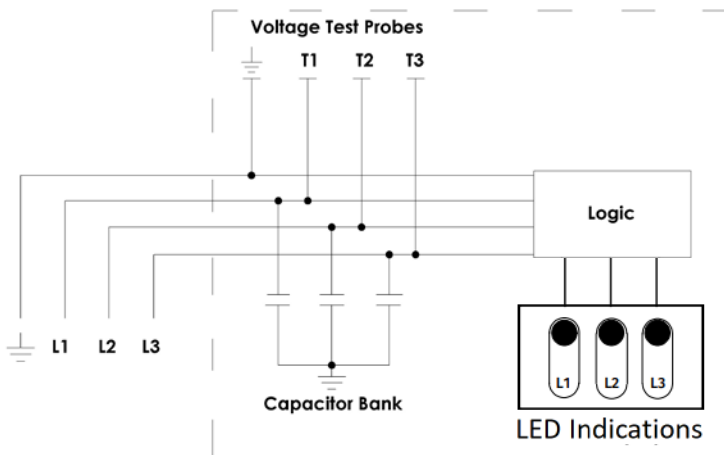

### Required data for order:

- Capacitance of coupling electrode C1
- C2 options; 3.3, 6.8, 10, 22, 47, 68, 80 nF
- Cable type and length
- Rated Voltage Un

**LRM Voltage Indicator: CVI**

The Capacitive Voltage Indicator is designed for to use with MV capacitive voltage divider devices.





**Features:**

- LRM system
- According to IEC 62271-213
- No auxiliary power is needed for voltage detection
- 3-Phase LCD display
- Easy for installation and maintenance
- Economical alternative

**Technical Parameters:**

1. Rated frequency : 50Hz or 60Hz
2. Threshold voltage : 10% to 45%Un
3. Operating temperature : -25°C to +55°C
4. Storage temperature : -30°C to +80°C
5. Protection class : IP54
6. Power freq. withstanding voltage: 2kV/1min
7. Connection leads : 4.8\*0.8mm fast-on terminals
8. Dimension : 96\*50\*50mm
9. Cutting size : 91\*45mm

INDICATION OF LCD	Indication with normal operation	Status of phase Voltage U
No indication	No Voltage	$U < 10\% * U_n$
	Voltage Present (light black arrow)	$10\% * U_n < U < 45\% * U_n$
	Nominal Voltage Present (full arrow)	$U > 45\% * U_n$

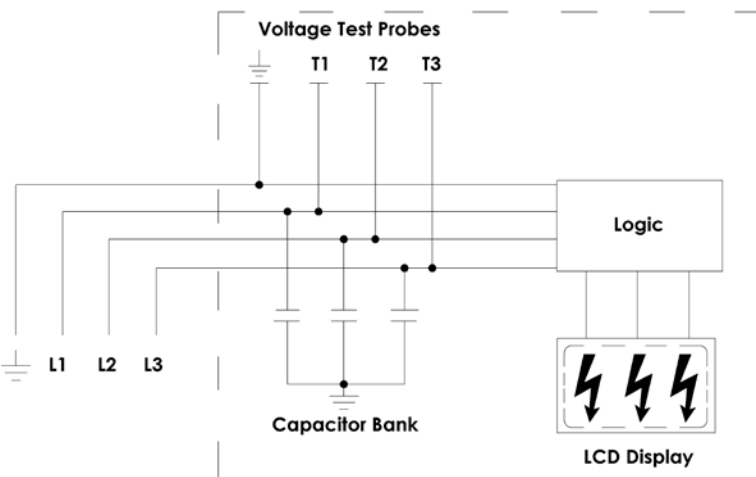

**Required data for order:**

- Capacitance of coupling electrode C1
- C2 options; 3.3, 6.8, 10, 22, 47, 68, 80 nF
- Cable type and length
- Rated Voltage Un

## LRM Voltage Indicator: CVI+

The Capacitive Voltage Indicator is designed for to use with MV capacitive voltage divider devices.



### Features:

- LRM system
- According to IEC 62271-213
- No auxiliary power is needed for voltage detection
- 3-Phase LCD display
- Easy for installation and maintenance
- Self-test function without any auxiliary power
- Bigger screen

### Technical Parameters:

1. Rated frequency : 50Hz or 60Hz
2. Threshold voltage : 10% to 45%Un
3. Operating temperature : -25°C to +55°C
4. Storage temperature : -30°C to +80°C
5. Protection class : IP54
6. Power freq. withstanding voltage: 2kV/1min
7. Connection leads : 4.8\*0.8mm fast-on terminals
8. Dimension : 96\*50\*50mm
9. Cutting size : 91\*45mm



INDICATION OF LCD	Indication with normal operation	Status of phase Voltage U
	Display TEST	-
No indication	No Voltage	$U < 10\% * U_n$
	Voltage Present (light black arrow)	$10\% * U_n < U < 45\% * U_n$
	Nominal Voltage Present (full arrow)	$U > 45\% * U_n$

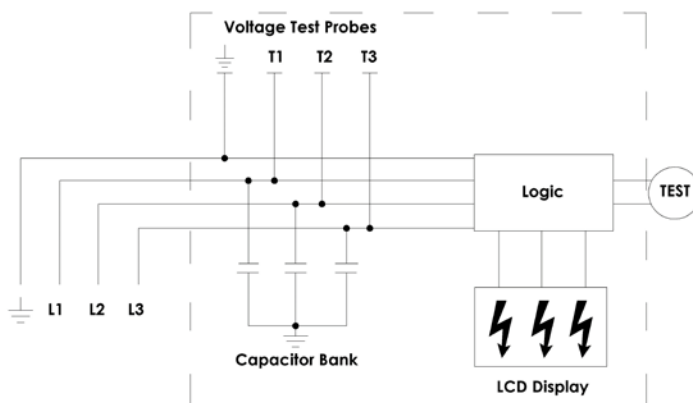

### Required data for order:

- Capacitance of coupling electrode C1
- C2 options; 3.3, 6.8, 10, 22, 47, 68, 80 nF
- Cable type and length
- Rated Voltage Un

**LRM Voltage Indicator: CVI S1**

**With 1 Relay Output**

The Capacitive Voltage Indicator is designed for to use with MV capacitive voltage divider devices.



**Features:**

- LRM system
- According to IEC 62271-213
- No auxiliary power is needed for voltage detection
- Wide auxiliary input range for relay power supply
- 3-Phase LCD display
- Change-over contact for status monitoring
- Easy for installation and maintenance

**Technical Parameters:**

- |                           |                           |
|---------------------------|---------------------------|
| 1. Rated frequency        | : 50Hz or 60Hz            |
| 2. Threshold voltage      | : 10% to 45%Un            |
| 3. Operating temperature: | -25°C to +55°C            |
| 4. Storage temperature    | : -30°C to +80°C          |
| 5. Protection class       | : IP54                    |
| 6. Connection leads       | : 4.8*0.8mm fast-on term. |
| 7. Dimension              | : 96*50*50mm              |
| 8. Cutting size           | : 91*45mm                 |
| 9. Contact output         | : 8A, 250VAC or 30VDC     |
| 10. Auxiliary power       | : 24 to 230V AC/DC        |
| 11. Power consumption     | : Less than 2W            |

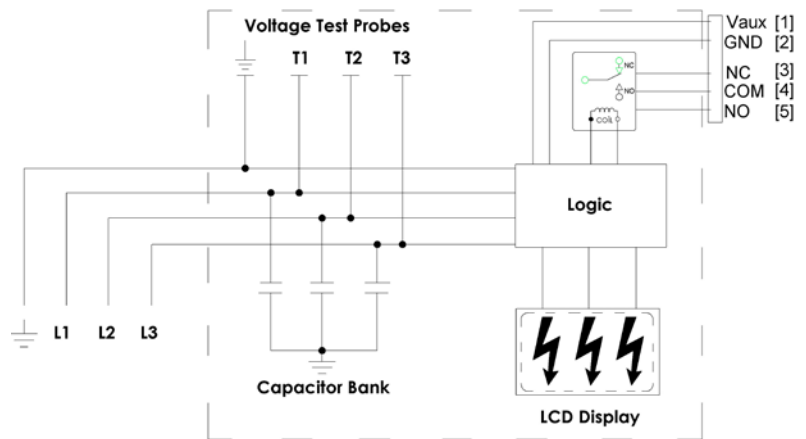

Capacitive voltage Indicator with relay output



LRM Voltage Indicator: CVI S1

Vaux status	Phase voltage	Type-1 Contact status	Type-2 Contact status
Off	For any status		
		<b>2-3</b>	<b>2-3</b>
On	All phases <%10 Un		
		<b>2-3</b>	<b>1-2</b>
On	At least one phase >%45 Un		
		<b>1-2</b>	<b>2-3</b>

Function table (Type-1):

Phase Voltage	Auxiliary Supply	Voltage Indication	Relay 1	
			NO-COM 1-2	NC-COM 2-3
<10%	Off	Off	Off	On
>45%	Off	On	Off	On
<10%	On	Off	Off	On
>45%	On	On	On	Off

Function table (Type-2):

Phase Voltage	Auxiliary Supply	Voltage Indication	Relay 1	
			NO-COM 1-2	NC-COM 2-3
<10%	Off	Off	Off	On
>45%	Off	On	Off	On
<10%	On	Off	On	Off
>45%	On	On	Off	On

Type-1 Terminal connection	Relay
1	NO
2	COM
3	NC
<b>Energy supply</b>	
4	Vaux (24-230 V AC/DC)
5	Gnd (-)

Type-2 Terminal connection	Relay
1	NO
2	COM
3	NC
<b>Energy supply</b>	
4	Vaux (24-230 V AC/DC)
5	Gnd (-)

Auxiliary Supply	Power (Red Led)
On	On
Off	Off

INDICATION OF LCD	Indication with normal operation	Status of phase Voltage U
No indication	No Voltage	$U < 10\% * U_n$
	Voltage Present (light black arrow)	$10\% * U_n < U < 45\% * U_n$
	Nominal Voltage Present (full arrow)	$U > 45\% * U_n$



Required data for order:

- Capacitance of coupling electrode C1
- C2 options; 3.3, 6.8, 10, 22, 47, 68, 80 nF
- Cable type and length
- Auxiliary power (24-230V AC/DC required)
- Options; type-1, type-2

**LRM Voltage Indicator: CVI+ S1**

**With 1 Relay Output**

The Capacitive Voltage Indicator is designed for to use with MV capacitive voltage divider devices.



**Features:**

- LRM system
- According to IEC 62271-213
- No auxiliary power is needed for voltage detection
- Wide auxiliary input range for relay power supply
- 3-Phase LCD display
- Change-over contact for status monitoring
- Easy for installation and maintenance
- Bigger screen

**Technical Parameters:**

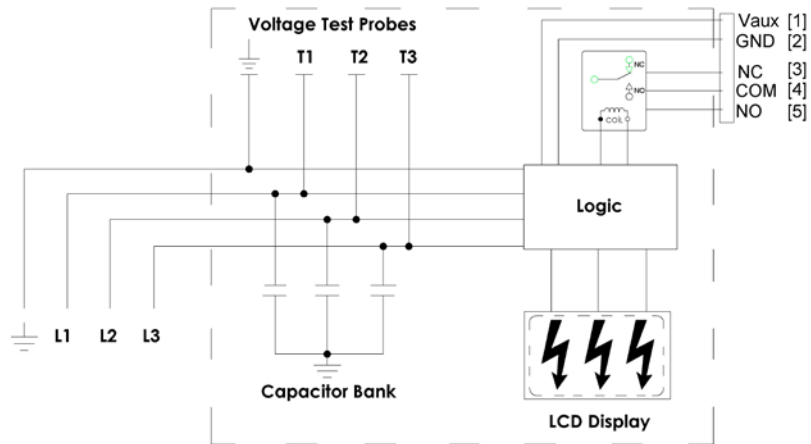

1. Rated frequency : 50Hz or 60Hz
2. Threshold voltage : 10% to 45%Un
3. Operating temperature: -25°C to +55°C
4. Storage temperature : -30°C to +80°C
5. Protection class : IP54
6. Connection leads : 4.8\*0.8mm fast-on term.
7. Dimension : 96\*50\*50mm
8. Cutting size : 91\*45mm
9. Contact output : 5A, 250VAC or 30VDC
10. Auxiliary power : 24 to 230V AC/DC
11. Power consumption : Less than 2W



Capacitive voltage Indicator with relay output

LRM Voltage Indicator: CVI+ S1

Indication Status:

INDICATION OF LCD	Indication with normal operation	Status of phase Voltage U
No indication	No Voltage	$U < 10\% * U_n$
	Display TEST	-
	Voltage Present (light black arrow)	$10\% * U_n < U < 45\% * U_n$
	Nominal Voltage Present (full arrow)	$U > 45\% * U_n$

Auxiliary Supply	Power (Red Led)
On	On
Off	Off

Function table (Type-1):

Phase Voltage	Auxiliary Supply	Voltage Indication	Relay 1	
			NO-COM 1-2	NC-COM 2-3
<10%	Off	Off	Off	On
>45%	Off	On	Off	On
<10%	On	Off	Off	On
>45%	On	On	On	Off

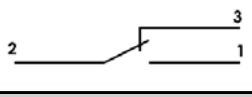
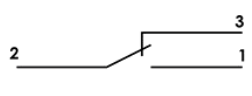
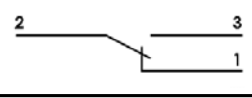
Vaux status	Phase voltage	Relay-1 Contact status
Off	For any status	 2-3
On	All phases <%10 Un	 2-3
On	At least one phase >%45 Un	 1-2

Type-1 Terminal connection	Relay
1	NO
2	COM
3	NC
<b>Energy supply</b>	
4	Vaux (24-230 V AC/DC)
5	Gnd (-)

Required data for order:

- Capacitance of coupling electrode C1
- C2 options; 3.3, 6.8, 10, 22, 47, 68, 80 nF
- Cable type and length
- Auxiliary power (24-230V AC/DC required)



**LRM Voltage indicator: CVI+S2**

**With 2 Relay Output**

The Capacitive Voltage Indicator is designed for to use with MV capacitive voltage divider devices.



**Features:**

- LRM system
- According to IEC 62271-213
- Self test function without any auxiliary power
- No auxiliary power is needed for voltage detection
- Wide auxiliary input range for relay power supply
- 3-Phase LCD display and bigger screen
- 2 LED indicators for contact status
- 2 Change-over contact for status monitoring
- Easy for installation and maintenance

**Technical Parameters:**

- 1.Rated frequency : 50Hz or 60Hz
- 2.Threshold voltage : 10% to 45%Un
- 3.Operating temperature: -25°C to +55°C
- 4.Storage temperature : -30°C to +80°C
- 5.Protection class : IP54
- 6.Connection leads : 4.8\*0.8mm faston term.
- 7.Dimension : 96\*50\*50mm
- 8.Cutting size : 92\*45mm
- 9.Contact output : 5A, 250VAC or 30VDC
- 10.Auxiliary power : 24 -230 AC/DC
- 11.Aux.Power isolation : 1.5 kV
- 12.Power consumption : Less than 2W

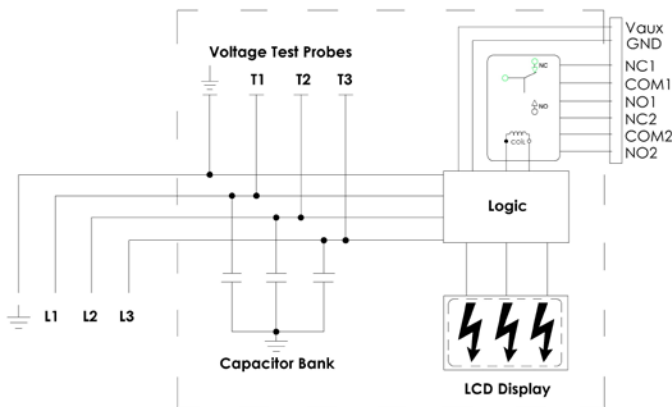

**Voltage indicator with 2 relay output**





**Function table:**

Phase Voltage	Auxiliary Supply	Voltage Indication	Relay 1		Relay 2	
			NO-COM 1-2	NC-COM 2-3	NO-COM 4-5	NC-COM 5-6
<10%	Off	Off	Off	On	Off	On
>45%	Off	On	Off	On	Off	On
<10%	On	Off	Off	On	On	Off
>45%	On	On	On	Off	Off	On

LRM Voltage indicator: **CVI+S2**

Indication Status:

INDICATION OF LCD	Indication with normal operation	Status of phase Voltage U
No indication	No Voltage	$U < 10\% * U_n$
	Display TEST	-
	Voltage Present (light black arrow)	$10\% * U_n < U < 45\% * U_n$
	Nominal Voltage Present (full arrow)	$U > 45\% * U_n$

HV on (Red Led)
On
Off

HV off (Green Led)
Off
On

Auxiliary Supply	Power (Red Led)
On	On
Off	Off

Relay function table:



Phase Voltage	Auxiliary Supply	Relay 1	
		NO-COM 1-2	NC-COM 2-3
Any Situation	Off	Off	On
All phases $U < 10\% U_n$	On	Off	On
At least 1 phase with $U > 45\% U_n$	On	On	Off

Phase Voltage	Auxiliary Supply	Relay 2	
		NO-COM 4-5	NC-COM 5-6
Any Situation	Off	Off	On
At least one phases $U < 10\% U_n$ or all phases $< 10\% U_n$	On	On	Off
All phases with $U > 45\% U_n$	On	Off	On

LRM Voltage indicator: **CVI+S2**

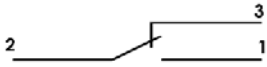
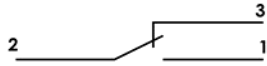
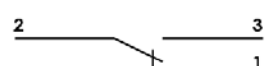
Relay function table:

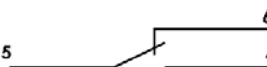
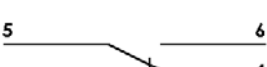
Vaux status	Phase voltage	Relay-1 Contact status
Off	For any status	 <p>2-3</p>
On	All phases <%10 Un	 <p>2-3</p>
On	At least one phase >%45 Un	 <p>1-2</p>

Vaux status	Phase voltage	Relay-2 Contact status
Off	For any status	 <p>5-6</p>
On	At least one phase <%10 Un or all phases <%10 Un	 <p>4-5</p>
On	All phases with U >45% Un	 <p>5-6</p>

Terminal connection	Relay 1
1	NO1
2	COM1
3	NC1
	<b>Relay 2</b>
4	NO2
5	COM2
6	NC2
	<b>Energy supply</b>
7	Vaux (24-230 V AC/DC)
8	Gnd (-)

Required data for order:

- Capacitance of coupling electrode C1
- C2 options; 3.3, 6.8, 10, 22, 47, 68, 80 nF
- Cable type and length
- Rated voltage Un
- Auxiliary power (24-230V AC/DC required)



## CVI T Phase Indicator

Phase comparator is designed for to indicate the state of high-voltage circuitry and check the phase sequence on the electrical equipment.

- LED Display
- No auxiliary power
- Self-test function without any auxiliary power
- Can be used with both LRM and HR Systems
- Easy to use



### FUNCTIONS

- Indication: Insert the phase comparator into the earth and other terminals of the high-voltage electrical equipment, the LED display will indicate if the line is energized.
- Phase Comparator: Insert the phase comparator into power terminals on the same phase sequence of two high-voltage electrical equipment, if the LED display has no indication the tested phase sequences are same.

### Technical Parameters:

- |                          |                  |
|--------------------------|------------------|
| 1. Rated frequency       | : 50Hz or 60Hz   |
| 2. Threshold voltage     | : 10% to 45%Un   |
| 3. Operating temperature | : -25°C to +55°C |
| 4. Storage temperature   | : -30°C to +80°C |
| 5. Protection class      | : IP54           |
| 6. Connection leads      | : 4 mm           |

## Resonance Damper

**Features:**

- LED signal for status tracking.
- Due to its low resistance when ferroresonance arises, it provides better damping than other damping resistors.
- Better power safety for earth-fault due to its high resistance during earth-fault.
- There is a one ferroresonance damper for secondary voltages between 100 and 120 VAC (open-delta).
- Activation time delay to keep other external protection devices unaffected.
- Small size compared to damping resistors.
- Saves space in customer application.
- Can be mounted low-voltage part on DIN-rail.
- One Damper for the protection of 3 voltage transformer with open-delta connection.

**Description:**

The resonance damper is a low voltage indoor switchgear device for elimination of ferroresonance phenomenon. It protects voltage transformers against potential ferroresonance overcurrent by prompt damping actions. Ferroresonance can arise in ungrounded power networks or in the network where is not directly grounded neutral point. It can occur between voltage transformer inductance and capacitances of system components. Transients in a system like switching can also trigger a ferroresonance stage which may cause a significant damage due to overvoltage and overcurrent surges caused by magnetic saturation of VT core. The device is determined to be used in cooperation with voltage transformers connected in open delta. The Damper is a smart (active) load instrument which eliminates these unwanted surges and protects voltage transformer when ferroresonance occurs. When input voltage is greater than the threshold voltage, the device activates and damping action is realized. It stays inactive up to threshold which is pre-defined as 20VAC. Thus the device shows no action against natural system asymmetry caused by phase imbalance. Threshold voltage can be set 20- 25-30VAC upon request by the manufacturer. There is a default 0.5s default time delay for activation after threshold is recognized and it can be set as 0.5s-1.5s- 2.5s-3.5s (by the manufacturer upon request), in order to keep the external protection device unaffected from damping process. If the voltage between terminals gets too high (or in the case of one phase is grounded), after pre-defined time, it automatically switches off to provide power safety for both itself and connected voltage transformers and after a certain time (according to thermal limits) tries to damp again. After the device being activated, it tries to damp the ferroresonance status until reaching a thermal limit (damping then cooling and afterwards damping). This function will protect the voltage transformers secondary windings from continuous high currents and over-heatings.



## Resonance Damper

### Technical Parameters:

- |                             |  |
|-----------------------------|--|
| 1. Nominal voltage          | :100-120VAC (open-delta)               |
| 2. Nominal Frequency        | :50/60Hz                               |
| 3. Activation Voltage       | :20VAC, 25VAC, 30VAC (20VAC default)   |
| 4. Activation Delay         | :0.5-1.5-2.5-3.5 sec (0.5 sec default) |
| 5. Damping time @ 120V      | :1 sec                                 |
| 6. Max. operational current | :14 A/1 sec                            |
| 7. Protection Class         | :IP20                                  |
| 8. Operating temperature    | :-25°C to +55°C                        |
| 9. Storage temperature      | :-40°C to +85°C                        |
| 10. Humidity                | :up to %90                             |
| 11. Dimensions              | :69 × 86 × 56 mm                       |
| 12. Weight                  | :0.15 kg                               |
| 13. Installation            | :35mm DIN rail (DIN EN 50 022)         |
| 14. Connection              | :Screw, 0.5 - 2.5 mm <sup>2</sup> wire |

### Connection Diagram:

LED Status	Description
Continuously ON	Damping action is in process
Blinking with ~ 1Hz	Cooling
Blinking with >>1Hz	Continuous over-voltage (earth-fault) or at thermal limits

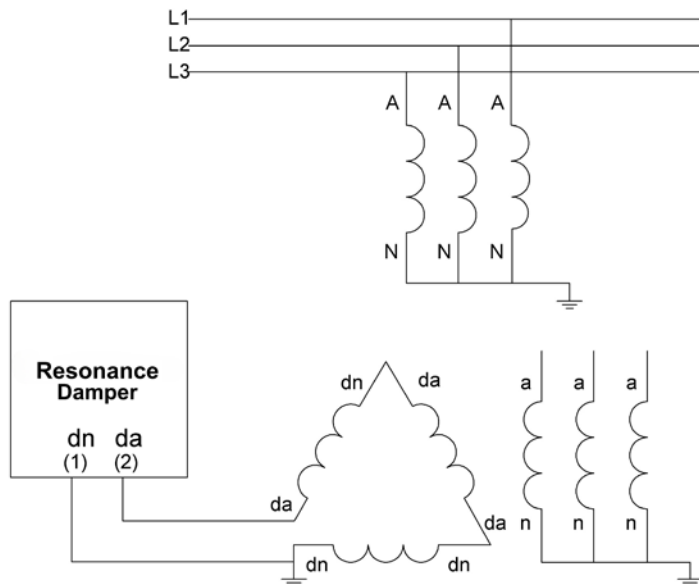

**LARA**

**LARA Elektromekanik Sanayi ve tic.ltd.**

Akan sokak, Yeni Darıca Kk Sanayi sitesi:2, No:20, 41700-DARICA/Kocaeli – Trkiye

[www.laraelectromechanical.com](http://www.laraelectromechanical.com)